

UNIT V RECENT TRENDS IN MEDICAL INSTRUMENTATION**9**

Telemedicine, Insulin Pumps, Radio pill, Endomicroscopy, Brain machine interface, Lab on a chip.

TELEMEDICINE:

- Telemedicine is the application of telecommunications and computer technology to deliver health care from one location to another.
- Telemedicine includes hardware, software, medical equipment and communications link.
- Telemedicine is the remote delivery of healthcare services over the telecommunications infrastructure.
- Telemedicine is a subset of telehealth, which includes both remote clinical service delivery and non-clinical elements of the healthcare system.

Applications of telemedicine:

- Teleradiology: Radiological images such as X-ray, CT or MRI images can be transferred from one location to another location for expert consultation. The process involves image acquisition and digitization.
- Telepathology: To obtain an expert opinion on the microscope images of pathology slides and biopsy reports.
- Telecardiology: Refers to the transmission of ECG, echo cardiography, colour doppler, etc.
- Teleeducation: Delivery of medical education programs to the physicians and the paramedics located at smaller towns who are isolated from major medical centres.
- Teleconsultation: Specialist doctor can be consulted either by a patient directly or by the local medical staff through telemedicine technology.

Telemedicine Concepts:

There are three main categories of telemedicine:

- *Remote patient monitoring* - allows patients with chronic diseases to be monitored in their homes through the use of devices that collect data about blood sugar levels, blood pressure or other vital signs. The data can be reviewed instantly by remote caregivers.
- *Store and forward technology* - stores clinical data, as well as X-rays and other images, and forwards the data to other locations for evaluation.
- *Interactive telemedicine* - allows physicians and patients to communicate in real time. Such sessions can be conducted in the patient's home or in a nearby medical facility.

Essential parameters for Telemedicine:

1. Primary patient data: Name, age, occupation, sex, address, telephone number, registration number etc.
2. Patient history: Personal and family history and diagnostic reports.

3. Clinical information: Signs and symptoms are interpretation of data obtained from direct and indirect patient observations.

Direct observation: data obtained from senses (sight, touch, sound, smell, etc) and through mental and physical interaction with patient.

Indirect observation: data obtained from diagnostic instruments such as temperature, pulse rate, blood pressure.

4. Investigations: Complete analysis reports of hematology and biochemistry test, urine examination.

5. Data and reports: Radiographs, MRI, CT, Ultrasounds and nuclear medicine images and reports, pathology slides, electrocardiogram, spirogram.

6. Video conferencing facility for online consultations.

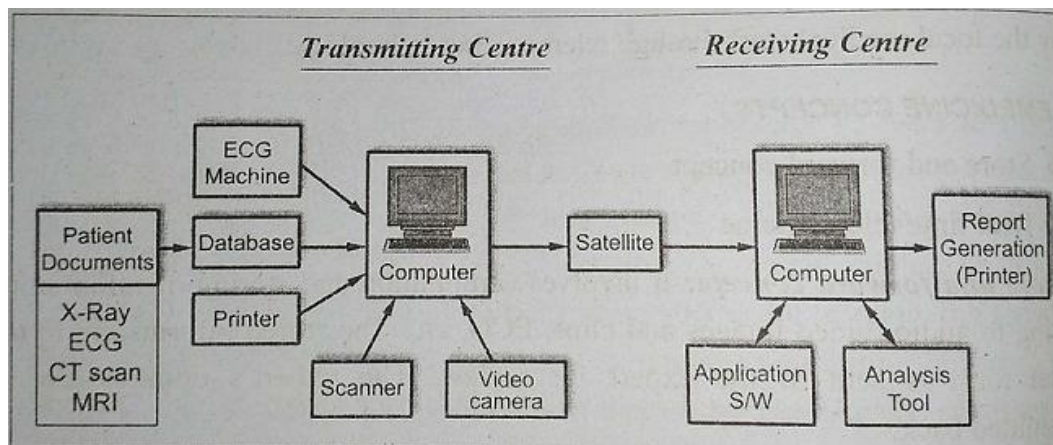
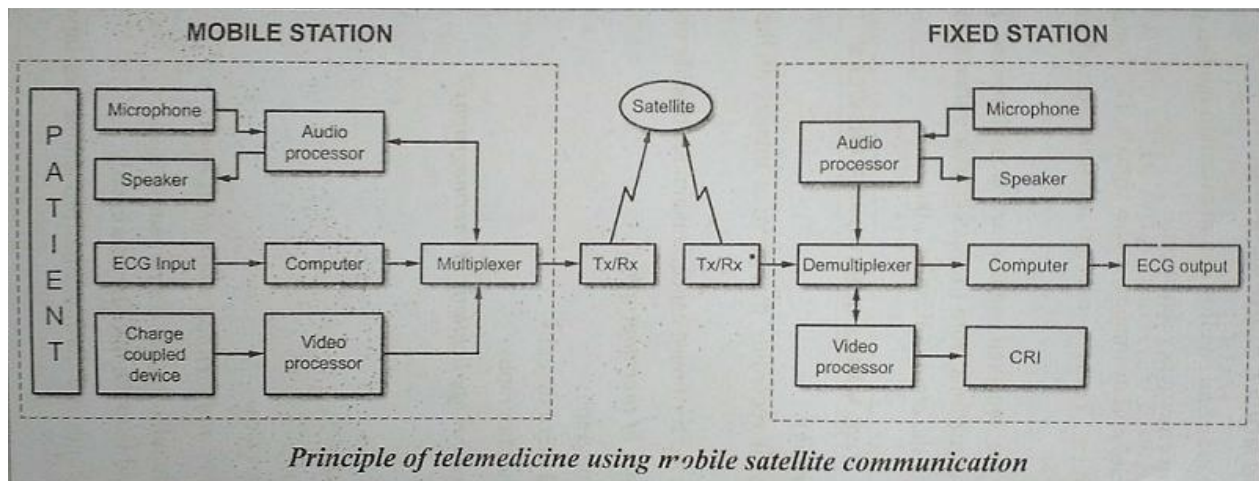

Fig: Block Diagram of a typical telemedicine system



Principle of telemedicine using mobile satellite communication

Telemedicine Technology:

- a) Transmission of medical images: One of the main aspects of telemedicine is the acquisition and transmission of medical images such as X-ray, CT, MRI, Histopathology slides etc. These images are converted into digital form.
- b) Transmission of video images: video clips, moving images, video conferencing, audio messages.

- c) Video conferencing: One of the essential components in a telemedicine system is the video conferencing facility, that permits transmission of both audio and video information.

Telemedicine using mobile communication:

- Mobile communication and satellite communication made a new possibility for mobile telemedicine in emergency situation.
- In a moving vehicle, colour images, audio signals, ECG and blood pressure are obtained from the patient. These signals are multiplexed and transmitted to a fixed station.
- In fixed station, the received signals are demultiplexed and presented to a medical specialist. Instructions from the specialist are then transmitted back to the mobile station through the communication link.

Advantage:

- Telemedicine can be beneficial to patients living in isolated communities and remote regions, who can receive care from doctors or specialists far away without the patient having to travel to visit them.
- Recent developments in mobile collaboration technology can allow healthcare professionals in multiple locations to share information and discuss patient issues as if they were in the same place.

Disadvantage:

- Major disadvantage of telemedicine is the inability to start treatment immediately.
- For example, a patient suffering from a bacterial infection might be given an antibiotic hypodermic injection in the clinic, and observed for any reaction, before that antibiotic is prescribed in pill form.

RADIO PILL

- Radio-pill is used in biotelemetry. It is the transmission of biological signal.
- In Radio-pill a transducer converts the signal to be measured in to an electrical form which can be amplified digitized so that it is suitable for transmission to other parts of system.

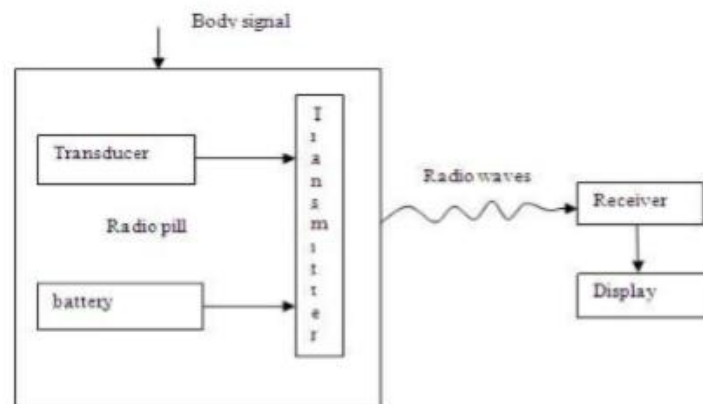

Fig: Block diagram of Radio pill

- The methods of communication are usually radio means and hence called radio telemetry. Other frequent uses are in monitoring patients who have certain conditions which put them at risk.
- In these cases, it may be necessary to implant the transducer transmitter and power supply in a single assembly is called Radio pill. The Radio pill is either swallowed or introduced surgically.
- The radio transmitter is essentially an electronic circuit which produces an alternating current (oscillator). This generates a radio wave which is detected in a corresponding receiver.
- The radio pill is capable of measuring various parameters. With the help of radio pill type devices, it is possible for use to measure or sense temperature, pH, enzyme activity, and oxygen tension values.
- These measurements can be made in associated with transducers. Pressure can be sensed by using variable inductance, temperature can be measured by using temperature-sensitive transducer.

TELEMETRY PRINCIPLES

Design considerations for a telemetry system

1. Simplicity of the telemetry system
2. Transmission should be with maximum fidelity
3. Telemetry components should be less weight and size
4. High reliability and stability is must
5. Power consumption should be small
6. Shielding of the cable is a must in wire-based transmission

Telemetry system:

- Telemetry is defined as the process by which the information regarding the quantity being measured transmitted to a remote location for application like data processing, recording or displaying.
- In other words, telemetry means measuring at a distance. Therefore, it becomes essential to transmit data through some form of communication channels.

Methods of classification of telemetry system:

- a) On the basis of the characteristics of electric signal such as voltage current position, frequency and pulse
- b) Based on form of data transmitted – analog and digital
- c) Based on transmission of distance – short distance type or long-distance type

d) Based on whether user has control over transmission channel or not.

- The physiological quantity to be measured by a suitable detector and given to the transmitter. The electrical telemetry system is broadly classified as DC systems and AC systems.

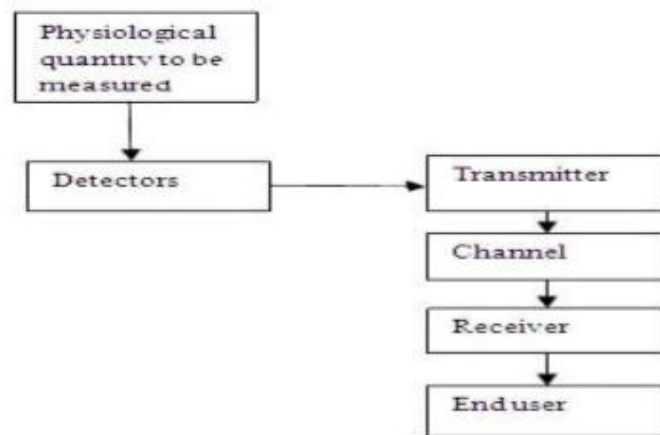

Fig: Telemetry system

DC telemetry system:

- The signal is transmitted through a telemetry or communication channel which uses direct transmission via cables in order to convey the desired information. This is known as land line telemetry.

AC telemetry system:

- It is used both for land line and radio frequency air borne telemetry techniques. Electronics means are used for sensors that provide an AC output or voltage to frequency converter.
- The data is available in the form of current or voltage which is generally weak. Hence It is modulated with carrier signals for transmission.
- These modulated signals are demodulated at the receiving end which means recovering the original signal from carrier wave. Basically, there are three types of modulation

Amplitude modulation: the amplitude of the carrier is varied in accordance with the signal to be transmitted.

Frequency modulation: the instantaneous frequency of the carrier is varied in accordance with the amplitude of the modulating signal.

Phase modulation: Here phase angle is varied in accordance to be transmitted signal.

Communication channels (or) Transmission media:

- The most widely used communication channels are cables and electromagnetic radiation radio links. Optical, ultrasonic and magnetic induction data links are also used for many applications.

- Land line telemetry utilizes cables or wires to transmit data. When data is to be transmitted for more than 1km radio links are preferred.
- For frequency above 30MHz microwave links are used. For short range transmission up to 50m frequency modulation used.

ENDOMICROSCOPY

- Optical fibers play a vital role in medical field. Endoscopes or fiberoscopes are designed with low quality, large diameter and short silica fibers.
- Broncho fiberoscopes, Gastrointestinal fiberoscopes and laparoscopes are the important endoscopes.
- Endoscopes are used in hospital for examination, treatment of diseases and surgery.
- There are two types 1. Flexible 2. Rigid
- In each endoscope, there are two fiber bundles. One is used to illuminate the inner structure of object. Other is used to collect the reflected light from that area and from that we can view the inner structure of object.
- Endoscope is an optical instrument to view the body cavities which are not visible to naked eye. Endoscope can be inserted to inspect or view the body cavities.
- The body is filled with air to improve optical transmission. The light is guided through the glass fibers by total internal reflection.
- A typical glass fiber consists of a central core glass having high refractive index surrounded by a cladding made of glass of slightly lower refractive index.
- The numerical aperture (light collection efficiency) of the fiber is equal to $(n_1^2 - n_2^2)^{1/2}$ where n_1 & n_2 are refractive index of core and cladding respectively.
- For better image quality, a telescope system is added in the internal part of endoscope. In the endoscope, at the object end there is an assembly of objective lens and prism and at the viewing end there is an eye lens.
- Endoscopic pictures can be recorded with color film and videotape recorders.



Fig:A flexible endoscope.



Fig: Observation using Endoscopy

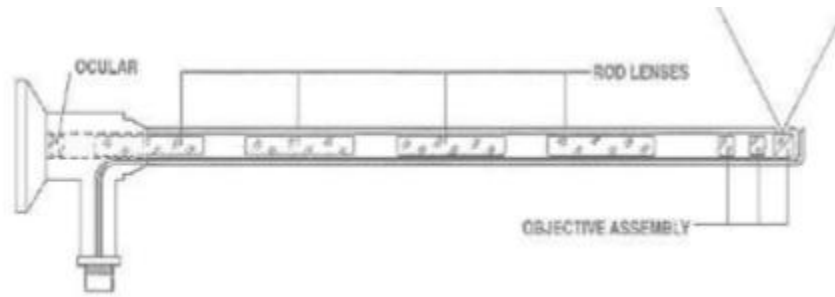

Fig: Rigid endoscope

Table: Difference types of commonly available endoscopes

| Type | Range of use | Diagnostic Problem or Operation |
|----------------|---------------------------------|--|
| Bronchoscope | Trachea larger airways | Foreign bodies infections aspiration of mucus |
| Cardioscope | Heart cavities | Valvular defects septal defect |
| Cystoscope | Urinary bladder | Tumors, inflammation, stones |
| Gastroscope | stomach | Gastritis, gastric ulcer, Tumors |
| Laparoscope | Abdominal cavity | Tumors, family planning operation |
| Ophthalmoscope | Eye fundus | State of vessels in high blood pressure, retinol detachment |
| Otoscope | Tympanic membranes | Infections perforation of ear drum pressure conditions in the middle ear |
| Proctoscope | rectum | Hemorrhoids |
| Sigmoidoscope | Rectum and distal part of colon | Bowel lesions, side pockets of the bowel |
| Thoracoscope | Pleural cavity | Tumors, air in the pleural cavity |

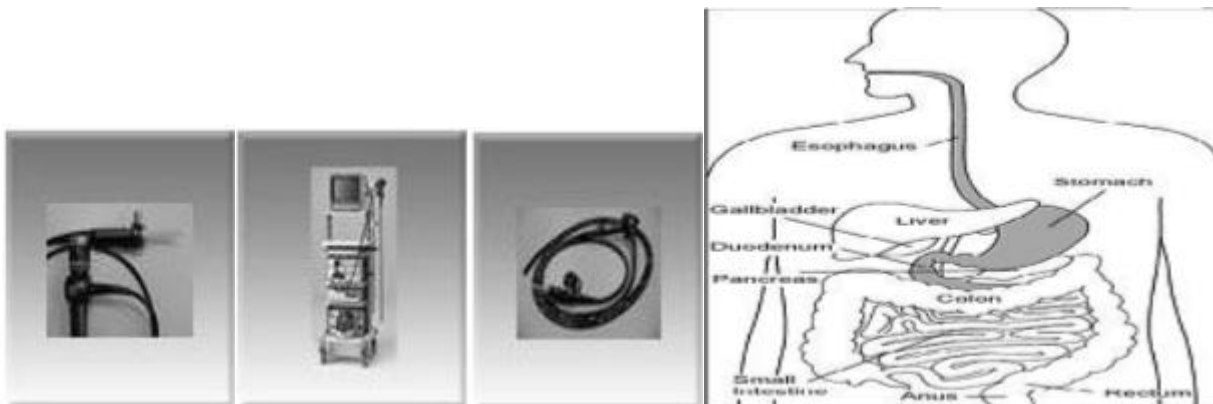

Fig: Endoscopic Equipment

Fig: Upper Endoscopy

Endoscopic Laser Coagulator

- It uses argon ion laser as high energy optical source and endoscope as the delivery unit.
- Argon ion lasers are very useful for the coagulation of blood vessels since its green light is highly absorbed by red blood vessels and hemoglobin.
- The absorption of green light result in the photocoagulation of blood protein and micro hemostasis. Argon ion laser is useful for the photocoagulation of retina because of their ability to do coagulation without affecting the surrounding healthy issue.

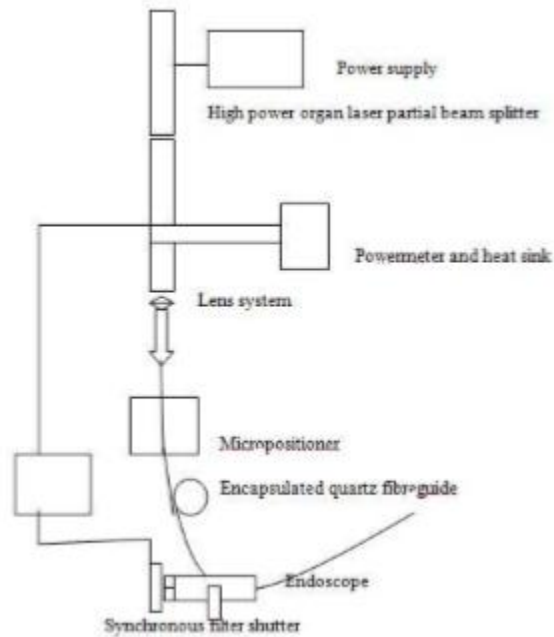

Fig: Endoscopic Laser coagulation

- To control gastric hemorrhage photocoagulation technique is adopted. In fiber optic endoscope, output from argon ion laser is delivered to required spot to arrest the gastric bleeding.
- We can move the laser beam in any direction with the flexible endoscope. The argon ion laser gives an output of 13w in the form of continuous waves.
- The diameter of quartz fiber endoscope is about 2mm.

PART A

1. What is meant by telemedicine?

Telemedicine is the remote diagnosis and treatment of patients by means of telecommunications technology.

2. Define - Endoscopes and mention some of its types. (May/June-2014)

Endoscope is a tubular optical instrument to inspect or view the body cavities which are not visible to the naked eye normally. Types of endoscopes are cardio scope, bronchoscope, laparoscope, hysteroscope, gastro scope etc.

3. List the applications of Endoscope.

Endoscopes are used in hospitals for examination, treatment of disease and surgery.

4. State the applications of telemedicine. (May/June 2016)

The applications of Telemedicine are

1. Tele-radiology – Radiological images like X-ray , CT or MRI Scan etc
2. Tele-pathology- microscopic images of pathology slides and biopsy reports
3. Tele-cardiology – Transmission of ECG , Echo ,Color Doppler
4. Tele-education – Delivery of medical education programmes to the physicians

5. What is a radio-pill? Mention the application. (May/June-2016)

The radio pill is capable of measuring various parameters. With the help of radio pill type devices, it is possible for use to measure or sense temperature, pH, enzyme activity, and oxygen tension values. These measurements can be made in associated with transducers. Pressure can be sensed by using variable inductance, temperature can be measured by using temperature-sensitive transducer

6. Define Let-go current. (Apr/ May 2008)(Nov/Dec2011) (Apr/May 2012)

Let-go current is the minimum current to produce muscular contraction. Let-go current for men is about 16 mA and for women is about 10.5 mA.

7. What is radio pill?(Apr/May2012)(April/May 2015)(May/June 2010)(Nov/Dec 2010) (Nov/Dec 2009)(May/June 2016)

Radio pill is used to monitor stomach pressure or pH. A pill consisting of a sensor and miniature transmitter is swallowed and the data are picked up by a receiver and recorded

8. List the parts of endoscope unit.(May/June 2013)

The parts of endoscope unit are:

1. High power argon laser
2. Partial beam splitter
3. Power meter and heat sink
4. Lens system
5. Micropositioner
6. Encapsulated quartz fibreguide
7. Endoscope
8. Synchronous filtershutter
9. Firing control and timing unit

9. What are the functions of endoscopy unit?(Nov/Dec 2008)

Endoscope is a tubular optical instrument to inspect or view the body cavities which are not visible to the naked eye normally. The endoscope is so designed for easy sterilization. In the endoscope, at the object end there is an assembly of objective lens and prism and at the viewing end, there is an eye lens. Endoscopic pictures can be recorded with color film and video tape recorder.

10. What are essential parameters for Telemedicine?

The essential parameters for telemedicine relating to a patient are

1. Primary patient data
2. Patient History
3. Clinical Information
4. Investigation
5. Data and Reports

11. Name the technologies used in telemedicine.

The technologies used in telemedicine are :

1. Transmission of Medical Images
2. Transmission of Video Images

3. Transmission of digital Audio
4. Video Conferencing
5. Digital Communication Systems
6. Telemedicine using Mobile Communication
7. Use of Internet resources for telemedicine

12. What is insulin pump?

It is a small device that gives your body the regular insulin it needs throughout the day

13. What are the types of Insulin pump?

Tethered pump-It is attached to your body by another small tube that connects to your cannula.
Patch Pump-It is attached directly to your body where you've chosen to place your cannula.

14. Mention the two insulin feed formats.

Bolus dose and Basal dose.

15. What are parts of Traditional insulin pumps?

Pumps, Tubing, Infusion set

16. What are the three main parts in patch pump?

Insulin reservoir Pumping mechanism Cannula

17. What are the components present in radiopill?

Radio pill consists of lens, antenna, transmitters, camera or sensors and battery.

18. What are types of radiopill?

- Pressure-sensitive pills
- Temperature sensitive pills
- pH sensitive pills

19. Mention the disadvantages in pressure sensitive pill?

A good seal between metal and Perspex was difficult to obtain.
Necessary to replace the diaphragm assembly quickly because damage can occur during recovery from the body.

20. What is Temperature sensitive radiopill?

It has been used for body core temperature monitoring.

21. Define Brain machine interface.

It is a device that translates neuronal information into commands capable of controlling external software or hardware such as a computer or Robotic arm.

22. What are the blocks consists of BMI?

- Signal acquisition
- Signal preprocessing
- Feature extraction
- Classification
- Application interface

23. Mention the application of BMI.

- EEG- based BCI system
- ECOG- based BCI systems
- Intracortical based BCI system.

24. Write the purpose of endomicroscopy.

Conventional wide field microscopy is unsuitable for imaging thick tissue because the images are corrupted by a blurred, out of focus background signal. Endomicroscope achieve optical sectioning using the confocal principles.

25. Classify the endomicroscopes.

- Single fibre endomicroscope
- Fibre bundle Endomicroscope
- Distal scanning endomicroscope
- Non confocal endomicroscope

26. What is Lab on chip?

It is a miniaturized device that integrates onto a single chip one or several analyses, which are usually done in a laboratory, analyses such as DNA sequencing or biochemical detection.